

Electrogenerated Chemiluminescence of BODIPY, Ru(bpy)₃²⁺, and 9,10-Diphenylanthracene Using Interdigitated Array Electrodes

Alexander B. Nepomnyashchii,[†] G. Kolesov,[#] and B. A. Parkinson^{*,†}

[†]Department of Chemistry and School of Energy Resources and [#]Department of Physics, University of Wyoming, Laramie, Wyoming 82071, United States

S Supporting Information

ABSTRACT: Interdigitated array electrodes (IDAs) were used to produce steady-state electrogenerated chemiluminescence (ECL) by annihilation of oxidized and reduced forms of a substituted boron dipyrromethene (BODIPY) dye, 9,10-diphenylanthracene (DPA), and ruthenium(II) tris(bipyridine) (Ru(bpy)₃²⁺). Digital simulations were in good agreement with the experimentally obtained currents and light outputs. Coreactant experiments, using tri-*n*-propylamine and benzoyl peroxide as a sacrificial homogeneous reductant or oxidant, show currents corresponding to electrode reactions of the dyes and not the oxidation or reduction of the coreactants. The results show that interdigitated arrays can produce stable ECL where the light intensity is magnified due to the larger currents as a consequence of feedback between generator and collector electrodes in the IDA. The light output for ECL is around 100 times higher than that obtained with regular planar electrodes with similar area.

KEYWORDS: steady-state electrogenerated chemiluminescence, collection efficiency, signal amplification, electrochemically pumped lasing

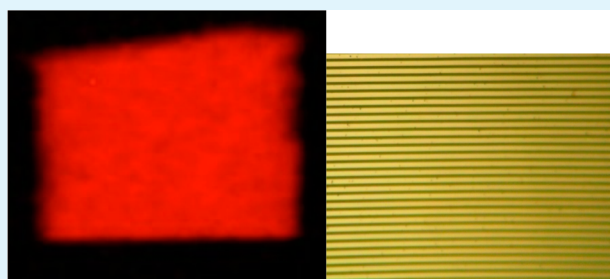

INTRODUCTION

Electrogenerated chemiluminescence (ECL) is a phenomenon concerned with electrochemical production of light by highly exothermic reactions between reducing and oxidizing species in solution near an electrode surface (Figure 1).^{1–3}

ECL has been shown to have applications in biological sensing and shown to be a potential means for achieving an electrochemically pumped laser.^{4–8} ECL contributes to a large commercial blood analysis application that is based on the

formation of a sandwiched avidin-streptavidin assay and Ru(bpy)₃²⁺ as the ECL active reagent.¹

There are two main mechanisms for ECL.^{1–3} The first is by annihilation of electrochemically generated oxidized and reduced species where the excess electronic energy results in one of the original molecules being produced in a fluorescent excited state, A*:



The second mechanism, the so-called coreactant mechanism, involves a species with a high oxidation or reduction potential in conjunction with a reduced or oxidized emitting compound. The generation of ECL with this mechanism is dependent on the nature of the coreactants. Mechanisms for the two different coreactants used herein, benzoyl peroxide (BPO) and tri-*n*-propylamine (TPrA), are proposed to go through either slow or fast catalytic process through the reaction between a radical anion or a radical cation (eqs 5–9) and strong oxidant or

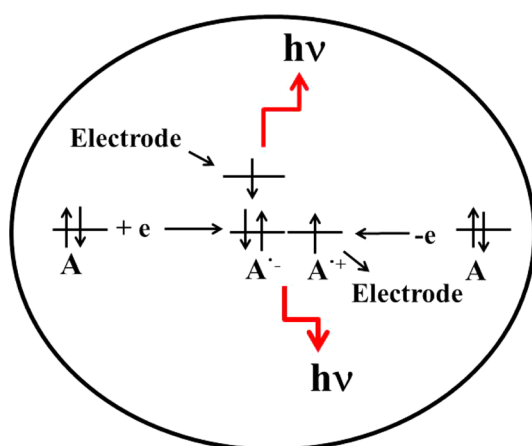

Figure 1. Schematic representation of ECL annihilation process.

Received: August 9, 2012

Accepted: June 5, 2013

Published: June 5, 2013

direct reduction of the BPO and oxidation of TPrA and reaction with radical anion or cation (eqs 10–14):^{9–13}

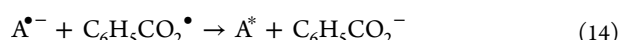
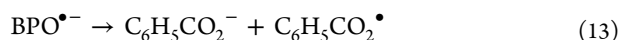
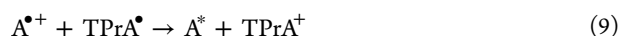
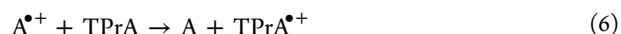

Most annihilation ECL experiments are done under potential step or potential sweep conditions governed by semi-infinite linear diffusion.¹ Though these are robust methods, the ECL intensity is limited due to the delay between the production of the highly oxidizing and reducing molecules and their diffusing together to react and form an excited state. Steady-state ECL experiments simultaneously and continuously produce radical cations and radical anions. The relatively few reports of steady-state ECL using rotating ring-disk, scanning electrochemical microscopy (SECM), and multiple band electrode experiments,^{14–18,20,21} mostly emphasize potential step techniques and ECL output stability.^{14–21} The few reports of electrogenerated chemiluminescence with annihilation using interdigitated array electrodes (IDAs)^{19,22} emphasize that IDAs can produce ECL via annihilation although actual steady-state conditions were not reported. In this work interdigitated array electrodes are used to generate ECL with both annihilation and coreactant modes. Representative dyes with good ECL yields and from three different dye classes, but with different electrochemical and ECL behavior, were chosen as systems for study: BODIPY (boron dipyrromethene), ruthenium(II) tris(bipyridine) Ru(bpy)₃²⁺, and 9,10-diphenylanthracene (DPA) whose structures are shown in Scheme 1.^{9,10,23–25}

Scheme 1. Structures of (a) BODIPY, (b) Ru(bpy)₃²⁺, and (c) DPA

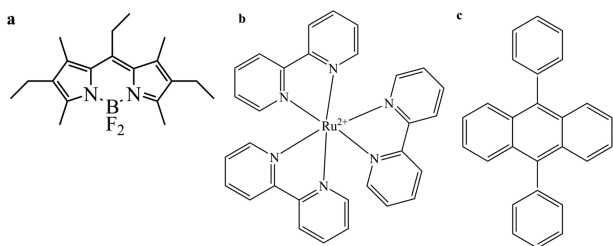

The mechanism of the feedback loop and the geometry of the IDAs is shown in Figure 2. The reduction occurs at the generator electrode, and feedback from multiple electrodes produces an increase in the steady-state current.

The IDA parameters that determine their electrochemical properties are described in Figure 2b and presented in eq 15, where i_{ss} is the steady-state current, m is the number of pairs of generator and collector electrodes, b is the length of the fingers,

wf is the electrode width, and wg is the gap between electrodes.²⁶ It is possible to achieve higher steady-state currents (i_{ss}) by increasing the number of collector and generator pairs, increasing the length of the fingers, increasing the electrode width, and decreasing the gap between generator and collector electrodes:

$$i_{ss} = nFDc^*mb(0.637 \ln(2.25(1 + wf/wg)) - 0.019/(1 + wf/wg)^2) \quad (15)$$

The other parameters in the equation (n is the number of electrons, F is the Faraday constant, D is the diffusion coefficient, and c^* is the bulk concentration) are constant throughout the experiment.

2. EXPERIMENTAL SECTION

2.1. Chemicals and Materials. The BODIPY dye (boron dipyrromethene) was obtained from Exciton Inc. (St. Louis, MO); DPA, Ru(bpy)₃ClO₄·6H₂O, electrochemically grade tetra-*n*-butylammonium hexafluorophosphate (TBAPF₆), tri-*n*-propylamine (TPrA), and anhydrous acetonitrile (MeCN, 99.93%) were provided by Sigma-Aldrich (Milwaukee, WI). Ru(bpy)₃ClO₄ was recrystallized prior to the experiments; platinum interdigitated arrays were provided by ALS (Tokyo, Japan) through CH instruments (Austin, TX); glassware was obtained from ACE glass (Vineland, NJ).

2.2. Experimental Details. Cyclic voltammetry experiments were done using a three-electrode cell configuration inside a nitrogen atmosphere glovebox (Vacuum Atmospheres Corp., CA). All electrochemistry experiments were done using IVIUM (Eindhoven, The Netherlands) potentiostats. A platinum electrode with an area of 0.0314 cm² was used as a working electrode with silver wire applied as a reference and platinum wire as a counter electrode. The working electrode was polished with 0.3 μm alumina (Buehler, Ltd., Lake Bluff, IL), sonicated in ethanol and water for 5 min, and dried in the oven under 120 °C prior to each experiment. Solutions were sealed inside of the glovebox using Teflon caps prior to transfer outside the box. Three stainless steel rods were inserted through the Teflon cap to ensure electrochemical connections. The reference electrode was calibrated using ferrocene solution assuming its potential to be 0.342 V vs SCE.²⁷ 0.1 M TBAPF₆ was used as supporting electrolyte in all experiments. Generation-collection experiments using IDAs were done in the similar setup with a fourth hole to connect the collector electrode. The IDA electrode consisted of 65 10 μm width pairs with a spacing of 5 μm and a length of 2 mm. The ECL intensity was monitored simultaneously with the current signal using an H10723-01 photomultiplier tube (Hamamatsu, Iwata City, Japan) and associated electronics connected to the computer through peripheral port expander. ECL spectra were generated using Princeton Instruments Spec-10 CCD camera (Trenton NJ) and an Acton SpectraPr-150 monochromator (Acton, MA). The wavelengths were calibrated using a Hg/Ar pen-ray lamp from Oriel (Stratford, CT). ECL spectra were measured by keeping the oxidation potential constant and scanning the reduction potential. Experiments with simultaneous production of the radical ions at steady-state conditions were also carried out.

2.3. Simulation Details. Digital simulations were carried out using finite difference method on an exponential grid according to ref 28. The Butler–Volmer formulation was used to calculate forward and backward rate constants for the electron transfer reactions. At each step these reactions were assumed to be nernstian, i.e. redox equilibrium concentrations of the species were calculated. For ECL reactions in solution the approach described in ref 29 was applied. A periodic boundary condition (PBC) was used to speed up calculations for the IDA electrode configuration. In this approach the simulation was set up with just one pair of electrodes with the gap space after the second electrode looped back onto the first electrode. The PBC was checked by comparison to an IDA with 65 electrode pairs. Only very small differences in simulated currents were seen that are attributed to species diffusing away from the outside electrodes that were

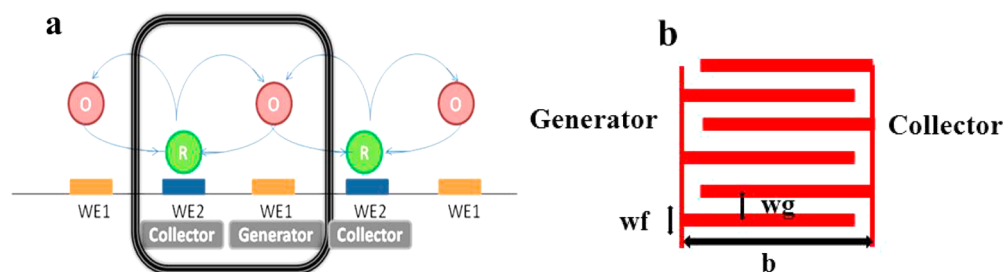

Figure 2. Generation collection mode diagram for an oxidation process (a) and schematic representation of the interdigitated array electrodes (b).

regenerated with the PBC assumption. Standard potentials were obtained from experimental results. The diffusion coefficients used for diffusing species in the simulations were set to 1.2×10^{-5} cm²/s. Further simulations details are described in the Supporting Information.

3. RESULTS AND DISCUSSION

3.1. Electrochemical Studies Using Interdigitated Arrays. The cyclic voltammogram of the BODIPY dye shows one oxidation and one reduction wave at about +1.2 V and -1.4 V, respectively (Figure 3a).²³ Cyclic voltammograms for Ru(bpy)₃²⁺ and DPA are well-known and not shown here.^{24,25,30,31}

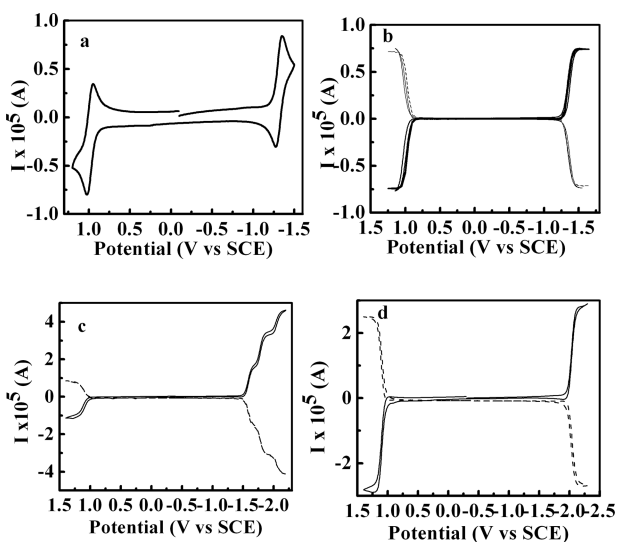

Figure 3. Cyclic voltammetry of (a) 0.7 mM BODIPY; generation-collection IDA electrode results for (b) 0.59 mM BODIPY, (c) 0.59 mM Ru(bpy)₃²⁺, (d) 1.20 mM DPA; scan rate: 0.05 V/s; number of pairs 65, width 10 μm, interval 5 μm, length: 2 mm. Collector was set at 0 V; solid and dashed lines are experimental and simulated currents; thick and thin lines for (b) are currents in generation and collection modes.

Figure 3b–d shows voltammograms with the expected steady-state currents at the generator and collector electrodes of the interdigitated array. In this experiment one of the electrodes (generator) is scanned to positive and negative potentials to oxidize and reduce BODIPY with the other electrode (collector) kept at a constant potential of 0 V, where no oxidation or reduction can occur (Figure 3a). Currents on the order of tens of microamps (Figure 3b–d) are measured for electroactive species concentrations of 0.70–1.20 mM for the IDAs in this work. The relatively large steady-state current values that can be obtained with small electrodes is the main

advantage of using IDAs. Experimental current voltage curves showed excellent agreement with the numerical simulations as shown in Figure 2b. The same IDA electrode voltammograms for Ru(bpy)₃²⁺ and DPA show characteristic behavior for those compounds with the expected presence of three waves for the ligand based reduction of Ru(bpy)₃²⁺ and one reduction wave for DPA and one wave for oxidation for both compounds (Figures 3c and 3d).

3.2. Electrogenerated Chemiluminescence. **3.2.1. Annihilation Studies.** Annihilation studies for ECL with the IDA electrode were initially carried out with the BODIPY dye without measuring the light intensity. The experimental results show a doubling of the current when scanning the potential in the negative direction while keeping the generator electrode at the potential where oxidation occurs (Figure 4a).

The currents and light output are also well fit by the simulations. The experiment when measuring ECL output shows some deviations from the simulation perhaps due to the instability of the IDAs, though the current is still close to steady state (Figure 4b–e). The light output also shows steady-state values corresponding to the second order kinetics. ECL light output is correlated fairly well with the current profile without any substantial offset seen.

An ECL signal is recorded over a range of 0.5 V for both the reduction and oxidation of BODIPY. The BODIPY dye shows interesting behavior with a large separation between the electrochemical waves due to the addition of the second electron to the molecule at around 0.9–1.0 V whereas aromatic hydrocarbons often have a separation of around 0.5 V (Table 1).²³ There is a decay of the light intensity for BODIPY with scanning the generator electrode to more negative potentials, but recovery of light output upon reversing the scan as seen in Figure 4b and d is unusual and unexpected since it does not follow the current flow. If contamination of the electrodes was occurring the light output would probably not recover upon reversing the scan. It is possible that some sort of concentration quenching is occurring upon increasing the rate of radical anion production. Further study would be needed to elucidate the mechanism for this ECL intensity behavior.

ECL from stable BODIPY compounds over a wide range of potentials (from around 0.94 to 2.30 V for oxidation and -1.37 V to -2.46 V for reduction) might allow for electrochemically pumped lasing in organic solvents if losses can be minimized in a properly designed laser cavity. The efficiency of ECL for this compound is around 20% relative to the ECL standard Ru(bpy)₃²⁺.¹⁰

ECL from annihilation for Ru(bpy)₃²⁺ shows the presence of three current waves with corresponding light output (Figures 5 and 6a).

In this case the decay of the light output is even more pronounced due to the presence of three electrochemical

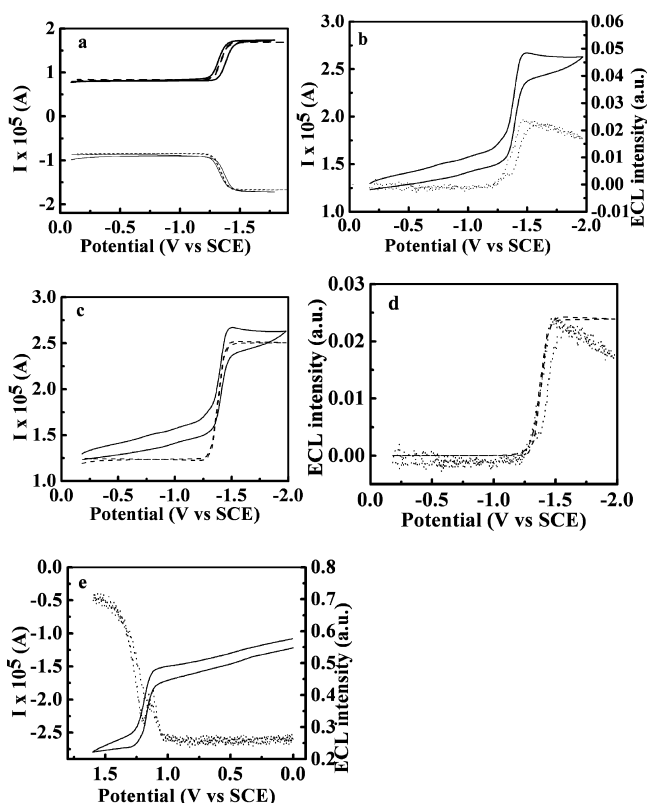

Figure 4. (a) Generation (thick lines)-collection (thin lines) IDA results for 0.60 mM BODIPY, solid and dashed lines are experimental and simulated results; (b) simultaneous ECL (dotted line)-current (solid line) profile for reduction of 0.89 mM BODIPY; (c) comparison of the experimental currents (solid line) with simulated (dashed line); (d) comparison of the experimental ECL results (solid line) with simulated (dotted line)); (e) simultaneous ECL (solid line)-current (dotted line) profile for oxidation of 0.63 mM BODIPY. The collector electrode was kept at +1.4 V for reduction and -1.6 V for oxidation; scan rate: 0.05 V/s; number of pairs 65, width 10 μm , interval 5 μm , length: 2 mm.

Table 1. Standard Potentials for Oxidation and Reduction of BODIPY, Ru(bpy) $_3^{2+}$, and DPA

process	compounds		
	BODIPY	Ru(bpy) $_3^{2+}$	DPA
E_{2ox}^0	2.30	3.42	1.70
E_{1ox}^0	0.94	1.25	1.27
E_{1r}^0	-1.37	-1.48	-2.10
E_{2r}^0	-2.46	-1.68	-2.60

waves. DPA shows one wave for the light and current for both oxidation and reduction similar to BODIPY although the reduction potential is around 1.0 V more negative and the potential for oxidation is slightly more positive (Figure 6b–d). ECL spectra for all three compounds were similar to those obtained from potential step experiments (Figure 7)^{23,25,32} implying the same excited state is produced in both experiments.

The detection limit for IDA-ECL from annihilation was in the subnanoampere range more than 100 times lower when compared to a conventional planar electrode of similar total area suggesting that the ECL output is correspondingly higher. The small size and easy mass production of IDAs may provide

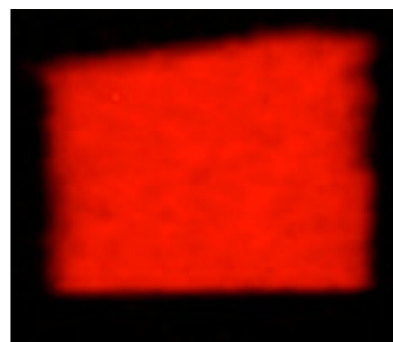

Figure 5. A photograph of the ECL obtained from Ru(bpy) $_3^{2+}$ annihilation with the collector electrode at +1.5 V and generator electrode at -1.6 V.

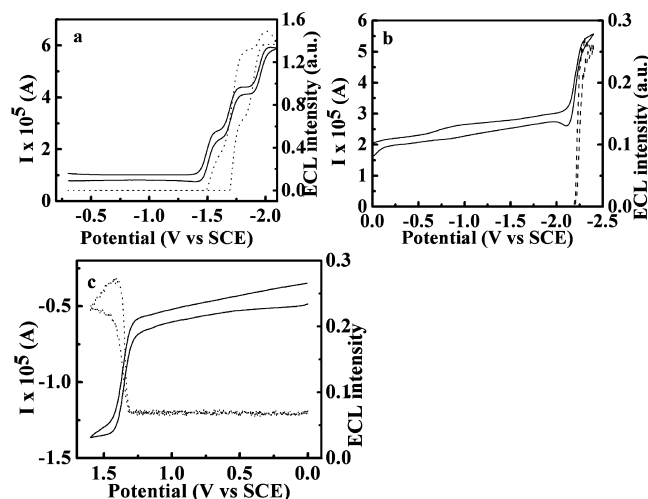

Figure 6. Simultaneous ECL (dotted line)-current (solid line) profile for (a) 0.59 mM Ru(bpy) $_3^{2+}$ with the collector electrode at +1.5 V; (b) and (c) ECL-current profile for 1.56 mM DPA for reduction and 0.3 mM for oxidation, keeping the collector potential at -2.25 V while scanning the generator in a positive direction and +1.5 for scanning in a negative direction; scan rate: 0.05 V/s; number of electrode pairs is 65, width 10 μm , spacing 5 μm , length: 2 mm.

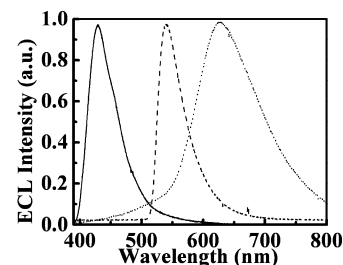

Figure 7. Electrogenenerated chemiluminescence spectra for DPA (solid line), BODIPY (dashed line), and Ru(bpy) $_3^{2+}$ (dotted line). The electrode was scanned in the negative direction where the reduction of the dyes occurs, and potentials at the collector were used for steady-state conditions; scan rate: 0.05 V/s; number of pairs 65, width 10 μm , interval 5 μm , length: 2 mm.

advantages for analytical applications compared to planar electrodes.

3.2.2. Coreactant Studies. IDA electrodes can provide useful information about the mechanism of coreactant ECL where there is competition between electron transfer processes and irreversible or quasi-reversible chemical kinetics between

the coreactant and the electrochemically produced oxidized or reduced dyes (Figure 8). In these studies collector was kept at

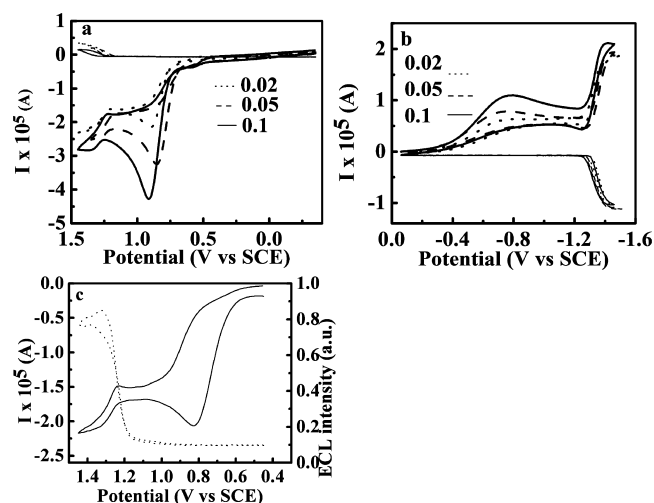

Figure 8. IDA electrode generation-collection voltammograms in the presence of 4 mM TPrA (a) and 1 mM benzoyl peroxide (b) at 0.02 V/s (solid line), 0.05 V/s (dashed line), and 0.1 V/s (dotted line): 0.31 mM Ru(bpy)₃²⁺ was used in case of (a) and 0.5 mM BODIPY in the case of (b); (c) simultaneous ECL (dotted line)-current (solid line) profile for oxidation of 0.31 mM Ru(bpy)₃²⁺ and 2 mM TPrA while keeping the potential of the collector electrode at 0 V; scan rate was 0.05 V/s; number of pairs 65, width 10 μm, interval 5 μm, length: 2 mm. The cathodic signal for reduction and anodic signal for oxidation are signals for generator and anodic signal for reduction, and the cathodic signal for oxidation are signals for collector.

the potential where no oxidation or reduction occurs, and the generator was scanned into the positive or negative direction depending on the coreactant used. The absence of a collection current, due to the fast irreversible decomposition of reduced BPO and oxidized TPrA, confirms that the radicals produced by reduction and oxidation by the electrochemically reduced or oxidized dyes (eqs 5–14) are short-lived.^{20,21} The collection efficiencies for redox cycling of BODIPY and Ru(bpy)₃²⁺ are independent of the concentration of coreactant. The stability of these species demonstrates the slow catalytic regeneration of the radical ions due to reaction with coreactants or direct electrochemical reduction of BPO or TPrA. Fast catalytic regeneration with a high turnover frequency can be completely ruled out in this case. A catalytic reaction (EC') with high turnover rate should cause substantial increase of the generation current with an increase in the amount of coreactant that was not observed (eqs 10 and 11). The exact mechanism of the coreactant activity cannot be elucidated, though current studies can provide useful hints for predicting the mechanism of the coreactant activity.

CONCLUSIONS

IDA electrodes were shown to produce a steady-state ECL, that was much more efficient than from conventional pulsed electrochemical generation from a planar electrode of a similar size, by simultaneous production of reduced and oxidized BODIPY, Ru(bpy)₃²⁺, and DPA dyes at the generator and collector electrodes. The BODIPY dye has a relatively stable ECL signal over a wide range of potentials as a consequence of the large separation between its electrochemical oxidation and reduction waves. The ECL intensity for the annihilation of

reduced and oxidized Ru(bpy)₃²⁺ is influenced by the presence of multiple redox states upon reduction of the Ru(bpy)₃²⁺ and for DPA by the very negative reduction potentials for DPA. Coreactant ECL intensity corresponds with the reduction or oxidation of the dyes as a consequence of the instability of the products of the decomposition of the coreactants TPrA and benzoyl peroxide.

ASSOCIATED CONTENT

Supporting Information

Additional simulation information. This material is available free of charge via the Internet at <http://pubs.acs.org>.

AUTHOR INFORMATION

Corresponding Author

*E-mail: bparkin1@uwyo.edu.

Notes

The authors declare no competing financial interest.

ACKNOWLEDGMENTS

This material is based upon work supported as part of the Center of Molecular Electrocatalysis, an Energy Frontier Research Center funded by the U.S. Department of Energy, Office of Science, Office of Basic Energy Sciences. We thank Fei Liu for help in preparation of the manuscript.

REFERENCES

- (1) *Electrogenerated Chemiluminescence*; Bard, A. J., Ed.; Marcel Dekker, Inc.: New York, NY, 2004.
- (2) Faulkner, L. R.; Bard, A. J. *Electroanalytical Chemistry*; Marcel Dekker; New York, 1977; Vol. 10, p 1.
- (3) Bard, A. J.; Debad, J. D.; Leland, J. K.; Sigal, G. B.; Wilbur, J. L.; Wohlstadter, J. N. In *Encyclopedia of Analytical Chemistry: Applications, Theory and Instrumentation*; Meyers, R. A., Ed.; John Wiley & Sons: New York, 2000; Vol. 11, p 9842.
- (4) Blackburn, G. F.; Shah, F.; Kenten, J. H.; Leland, J.; Kamin, R. A.; Link, J.; Peterman, J.; Powell, M.; Shah, A.; Talley, D. B. *Clin. Chem.* **1991**, *37*, 1534–1539.
- (5) Kenten, J. H.; Gudibande, S.; Link, J.; Willey, J. J.; Curfman, B. O.; Major, E. O.; Massey, R. J. *Clin. Chem.* **1992**, *38*, 873–879.
- (6) Keszthelyi, C. P. *Appl. Opt.* **1974**, *14*, 1710–1712.
- (7) Measures, R. M. *Appl. Opt.* **1974**, *13*, 1121–1133.
- (8) Tsutomu, H.; Osamu, N.; Noriyuki, H. *Nature* **1998**, *394*, 659–661.
- (9) Sartin, M. M.; Camerel, F.; Ziesel, R.; Bard, A. J. *J. Phys. Chem. C* **2008**, *112*, 10833–10841.
- (10) Lai, R. Y.; Bard, A. J. *J. Phys. Chem. A* **2003**, *107*, 3335–3340.
- (11) Chandross, E. A.; Sonntag, F. I. *J. Am. Chem. Soc.* **1966**, *88*, 1089–1096.
- (12) Santa Cruz, T. D.; Akins, D. L.; Birke, R. L. *J. Am. Chem. Soc.* **1976**, *98*, 1677–1682.
- (13) Akins, D. L.; Birke, R. L. *Chem. Phys. Lett.* **1974**, *29*, 428–435.
- (14) Maloy, J. T.; Bard, A. J. *J. Am. Chem. Soc.* **1971**, *93*, 5968–5981.
- (15) Maloy, J. T.; Prater, K. B.; Bard, A. J. *J. Am. Chem. Soc.* **1971**, *93*, 5959–5968.
- (16) Bartelt, J. E.; Drew, S. M.; Wightman, R. M. *J. Electrochem. Soc.* **1992**, *139*, 70–74.
- (17) Amatore, C.; Fosset, B.; Maness, K. M.; Wightman, R. M. *Anal. Chem.* **1993**, *65*, 2311–2316.
- (18) Amatore, C.; Oleinick, A.; Svir, I. *Electrochem. Commun.* **2003**, *5*, 989–984.
- (19) Chidsey, C.; Feldman, B. J.; Lundgren, C.; Murray, R. W. *Anal. Chem.* **1986**, *58*, 601–607.
- (20) Miao, W.; Choi, J. P.; Bard, A. J. *J. Am. Chem. Soc.* **2002**, *124*, 14478–14485.

- (21) Fan, F.-R.; Cliffl, D.; Bard, A. J. *Anal. Chem.* **1998**, *70*, 2941–2948.
- (22) Fiaccabrino, G. C.; Zwahlen, P.; Thiebaud, P.; Racine, G. A.; Rooij, N. F.; Koudelka-Hep, M. *IEEE* **1997**, 171–174.
- (23) Nepomnyashchii, A. B.; Cho, S.; Rossky, P. J.; Bard, A. J. *J. Am. Chem. Soc.* **2010**, *132*, 17550–17559.
- (24) Santhanam, K. S. V.; Bard, A. J. *J. Am. Chem. Soc.* **1965**, *87*, 139–140.
- (25) Tokel, N. E.; Bard, A. J. *J. Am. Chem. Soc.* **1972**, *94*, 2862–2863.
- (26) Cohen, A. E.; Kunz, R. *Sens. Actuators, B* **2000**, *62*, 23–29.
- (27) Sahami, S.; Weaver, M. J. *Electroanal. Chem.* **1981**, *122*, 155–170.
- (28) Bard, A. J.; Crayston, J. A.; Kittlesen, G. P.; Varco Shea, T.; Wrighton, M. S. *Anal. Chem.* **1986**, *58*, 2321–2331.
- (29) Varco Shea, T.; Bard, A. J. *Anal. Chem.* **1987**, *59*, 2101–2111.
- (30) Santhanam, K. S. V.; Bard, A. J. *J. Am. Chem. Soc.* **1966**, *88*, 2669–2674.
- (31) Tinker, L. A.; Bard, A. J. *J. Am. Chem. Soc.* **1979**, *101*, 2316–2319.